

Elevator Technology

thyssenkrupp Elevator AG
thyssenkrupp Allee 1
45143 Essen
Germany
www.thyssenkrupp-elevator.com

Elevator Technology

Velino Classic

Sophisticated
simplicity



thyssenkrupp

Individual details given in this publication are guaranteed only if confirmed expressly in writing and in each respective case.

EN.V2.04.2016

engineering.tomorrow.together.



Velino Classic. Simply best in class.

High-quality technology.

Velino Classic features proven technology, open profiles in truss design, track systems manufactured in house, and controllers tested in house. Its precise mechanical assembly and intelligent control systems are designed to move passengers from one level to the next smoothly and safely.

Energy efficiency.

The LED lighting in the Velino Classic uses up to 90% less energy than fluorescent lighting, for example. In addition, you can choose from a range of optional energy-saving features. During the service life of an escalator you will save running costs.

Utmost safety.

Velino Classic incorporates a full set of standard safety features to comply with international standards such as EN115 or GB16899. But since this escalator's additional safety features actually surpass the code requirements, you can rest assured that passenger safety will never be compromised.

Great value for money.

Velino Classic performs to perfection thanks to thyssenkrupp's renowned high standards in materials and manufacturing, while at the same time offering great value for money. So you can save on running costs during the escalator's service life.



Aesthetic kinetics. Simply stunning from every perspective.

Unique handrail inlet.

The unique flap system with its two-door release mechanism means there are no brushes or rubber guards – and that gives Velino Classic a pleasingly modern look.



Matching plates.

The standard configuration features structured stainless-steel floor and comb plates. Optionally you can choose bar-ribbed plain or black aluminum ones.



Attractive decking profiles.

Velino Classic comes with silver anodized aluminum deckings as standard. The stainless-steel option is more scratch- and mark-resistant for longer-lasting good looks.



Appealing steps.

Several design options are available: silver and black without yellow demarcation; silver and black with yellow plastic inserts; and silver with yellow demarcation.

An escalator is not just a functional object. It has to look the part too. And that's why Velino Classic is designed to give as much aesthetic appeal as it does functional pleasure. However you look at Velino Classic it's simply a stunning escalator.

- More attractive and more functional thanks to our unique handrail inlet.
- Refined lighting options like the under-handrail lighting enhance the aesthetics.
- Appealing choices of comb and floor plates enable every unit to blend in with its surroundings.



Custom lighting.

Five lighting options: skirt band lighting, comb lighting, step gap lighting, under-handrail lighting, and bi-color traffic lights at the inner decking – so your building really will shine bright.

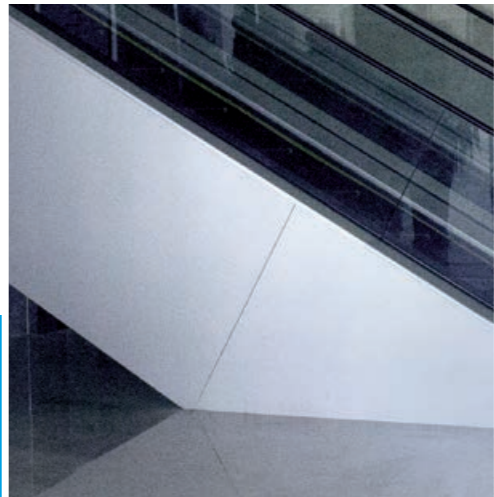

Attractive lateral cladding.

Two lateral cladding options are available on request: brushed stainless steel or powder-coated steel sheeting (in white or silver).



Solid skirt.

The skirt comes in carbon steel with black safety painting as standard, or optionally in brushed stainless steel with or without transparent anti-friction painting.



Colorful handrail.

The handrail comes in black as standard but is also available in all possible color options to perfectly match your building's color scheme.

thyssenkrupp engineering. Quality you can simply trust.

German engineering is renowned all over the world for its high-class quality. Velino Classic is no exception. It is built to the highest quality standards – simply a great investment.

- Key components are built in house to comply with the highest international standards.
- Precise laser alignments make every escalator a perfect fit.
- Rigorous testing facilities guarantee highest thyssenkrupp quality.



Built to last.

During assembly of the truss we use lasers to align the key elements to ensure a perfect fit. The bottom plate of our anti-corrosion painted truss is continuously welded to prevent dangerous oil stains. Most importantly, our angle steel complies with BS EN 1993 and is EN1090 certified.



Reliable steps.

Built to our own design, the steps offer utmost reliability with minimal risk of breakage. In a dynamic load test they performed 50% better than the EN 115 standard.

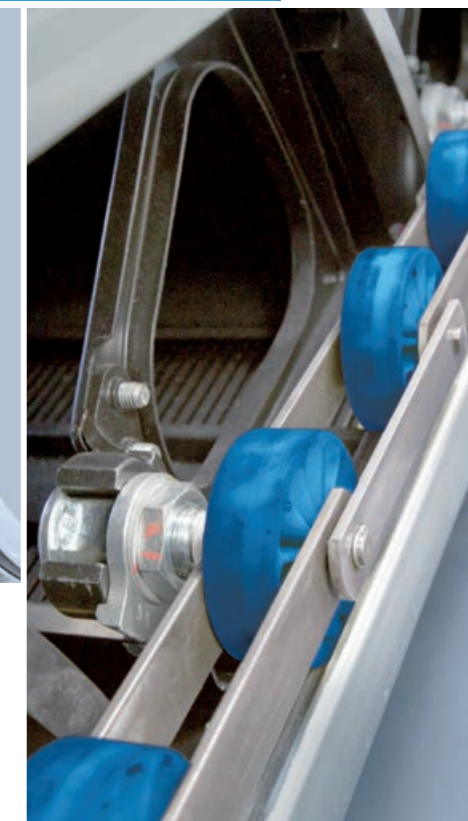

Smooth-running track system.

Manufactured in house, the track system is also assembled using laser-precision jigs to ensure minimal noise, vibration and abrasion, which in turn results in a quiet and efficient operation and reliably long roller life. The outcome is a smooth and quiet ride for passengers – quality you and your customers can actually feel.

The safety of your passengers is our top priority. With our renowned safety options, you can rest assured that your Velino Classic will simply outpace your country's regulatory requirements.

- Velino Classic complies with the latest international safety codes.
- Additional safety options mitigate the risk of incidents caused by misuse.



Safety first. It's simply in our DNA.

Sensible safety options.

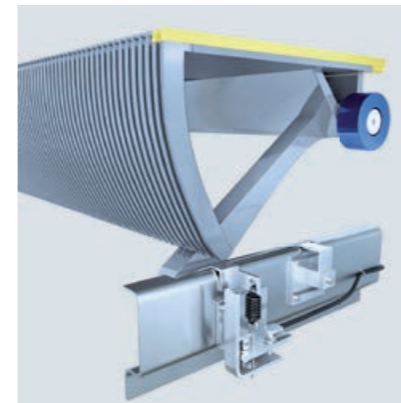

Step up-thrust device.

The step up-thrust monitoring device shuts down the escalator as soon as objects become trapped in the gap between two consecutive steps, thus reducing the risk of step breakage.



Double shoe brake system.

When one brake fails, the other will continue to operate thanks to a dual circuit in which each one has its own brake shoe. This makes sure the escalator will stop safely under any circumstances, thus ensuring your passengers' safety.

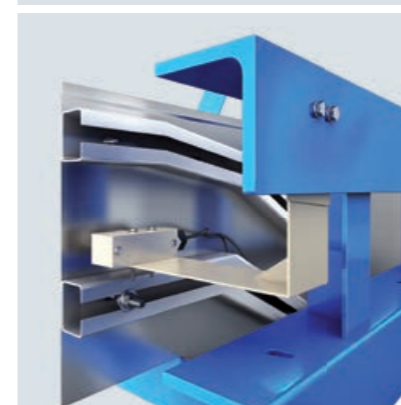

Skirt safety switches.

Since these switches react immediately if something gets trapped between the steps and the skirt, Velino Classic is safer for children and people wearing high-friction rubber boots, for example.

Velino Classic		
	Standard	Option
Stop button	<input checked="" type="checkbox"/>	<input type="checkbox"/>
Stop button with covers	<input type="checkbox"/>	<input checked="" type="checkbox"/>
Key switch at top	<input checked="" type="checkbox"/>	<input type="checkbox"/>
Key switch at top and bottom	<input type="checkbox"/>	<input checked="" type="checkbox"/>
Comb plate switch	<input checked="" type="checkbox"/>	<input type="checkbox"/>
Handrail inlet guide	<input checked="" type="checkbox"/>	<input type="checkbox"/>
Chain tension switch	<input checked="" type="checkbox"/>	<input type="checkbox"/>
Step run guard	<input checked="" type="checkbox"/>	<input type="checkbox"/>
Speed monitoring	<input checked="" type="checkbox"/>	<input type="checkbox"/>
Full motor protection	<input checked="" type="checkbox"/>	<input type="checkbox"/>
Fault-current circuit breaker	<input checked="" type="checkbox"/>	<input type="checkbox"/>
Phase sequence relay	<input checked="" type="checkbox"/>	<input type="checkbox"/>
Skirt brush/rubber deflector	<input checked="" type="checkbox"/>	<input type="checkbox"/>
Skirt safety switches	<input type="checkbox"/>	<input checked="" type="checkbox"/>
Drive chain monitoring*	<input checked="" type="checkbox"/>	<input type="checkbox"/>
Brake wear indicator	<input type="checkbox"/>	<input checked="" type="checkbox"/>
Brake function indicator	<input checked="" type="checkbox"/>	<input type="checkbox"/>
Missing step indicator	<input checked="" type="checkbox"/>	<input type="checkbox"/>
Handrail speed monitoring	<input checked="" type="checkbox"/>	<input type="checkbox"/>
Handrail broken device	<input type="checkbox"/>	<input checked="" type="checkbox"/>
Step up-thrust device	<input type="checkbox"/>	<input checked="" type="checkbox"/>
Cover plate contacts	<input checked="" type="checkbox"/>	<input type="checkbox"/>
Fire alarm shut-down switch	<input type="checkbox"/>	<input checked="" type="checkbox"/>
Anti-climbing barrier	<input checked="" type="checkbox"/>	<input type="checkbox"/>

* standard only for EN115



Sustainability pays off – simply better to have green solutions.

Energy-saving STAR-DELTA.

This optional device makes up to 15% energy savings possible when no passengers are on the escalator. After the escalator is switched on, the motor stays at a third of its nominal power and only switches to full power when a passenger passes the light barrier in the skirt.

Energy-saving stop-and-go.

In the absence of any passengers on the step band, the escalator comes to a smooth stop after a defined period of time. This intermittent operation function reduces power consumption and your electricity bill.

Energy-saving VVVF.

The Variable Voltage Variable Frequency (VVVF) drive slows the escalator down to standby speed when no passengers are detected. The frequency converter shows an approaching passenger the escalator's ready mode and direction of travel and helps to reduce energy consumption.

LED lighting.

LEDs not only last significantly longer than any other form of lighting, they also use a lot less energy. In other words, LEDs are both cost-efficient and environmentally friendly.

Many people still think that green solutions are more expensive. Our Velino Classic proves that sustainability pays off. This escalator puts sustainable efficiency into operational practice so it makes good business sense.

- State-of-the-art LED technology lasts longer and saves energy compared to conventional lighting.
- Depending on your load cases, operational modes may boost sustainability.

Mode of operation.

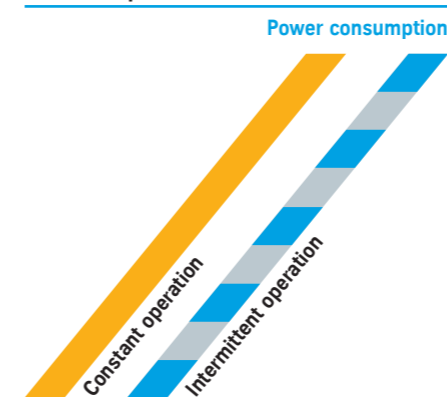

Lighting energy consumption.

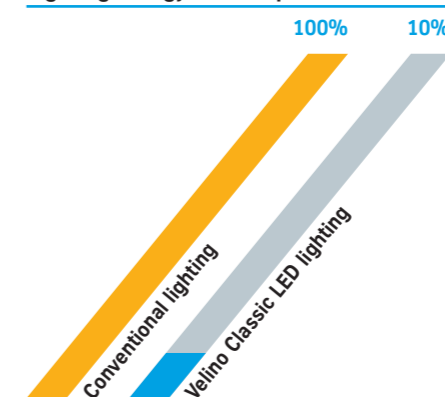

Lighting lifetime.

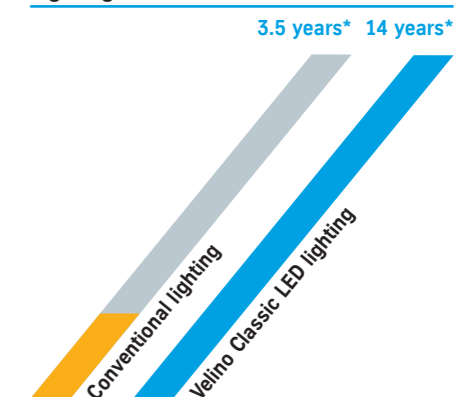

* 12 hours a day, 7 days a week

Straight to the point: All the facts and figures.

30° configuration
Side elevation

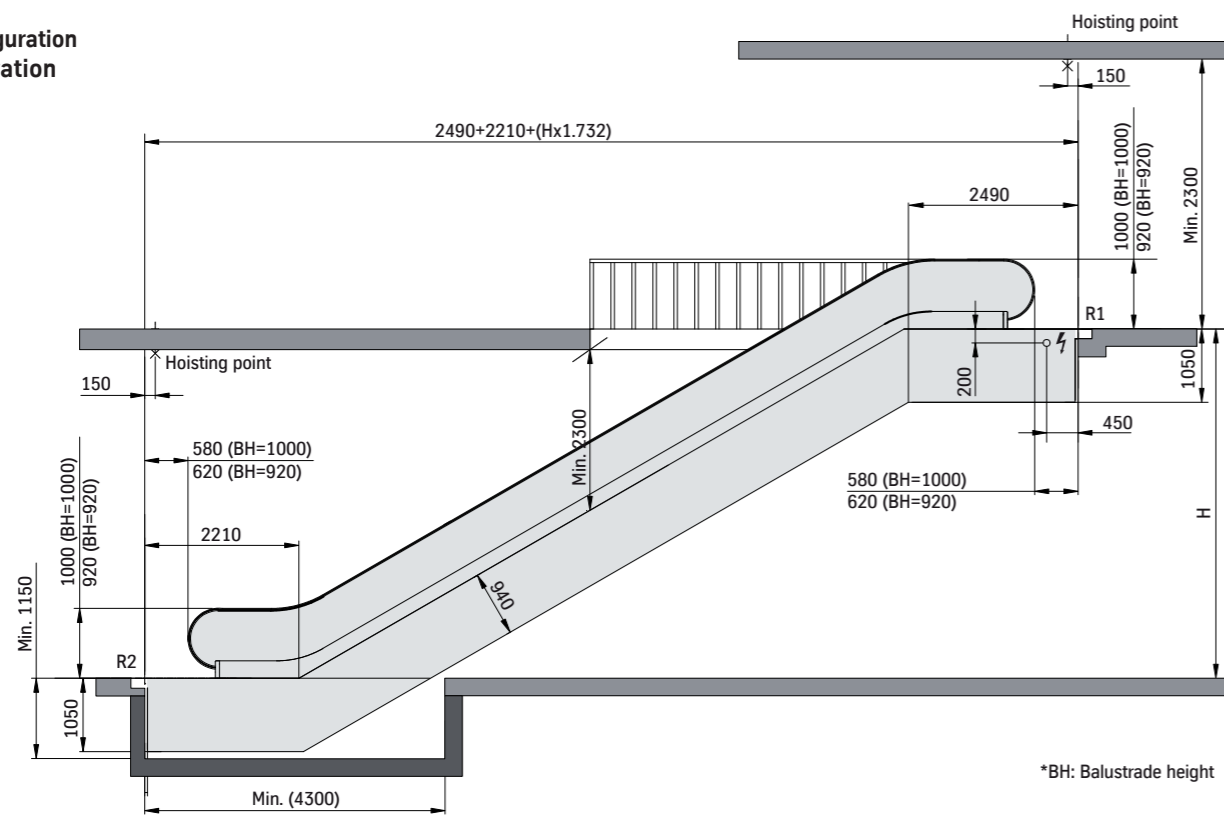

Plan view

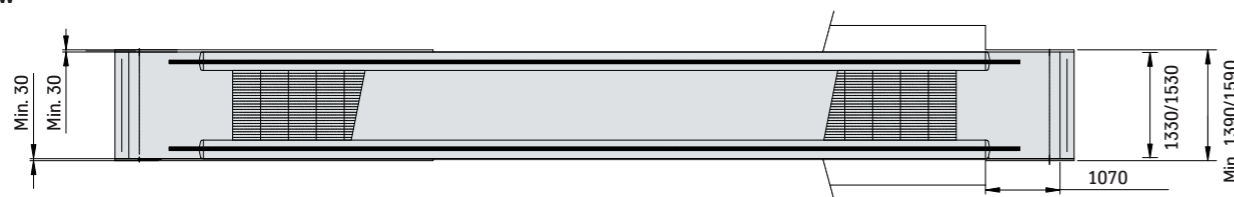

End support

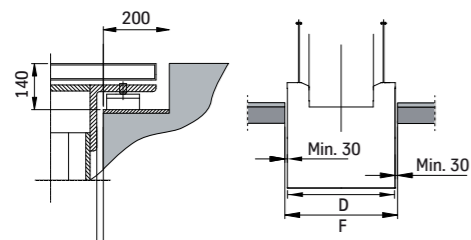

Basic parameters.

Travel speed	0.5m/s
Min./max. travel height	2m/6m
Number of horizontal transition steps	2
Nominal step width	800 mm or 1,000 mm
Top transition radius	1,050mm
Bottom transition radius	1,050mm

Climatic conditions.

Operating environment	Indoors
Temperature	+12° C to +35° C
Relative humidity	Max. 75%
Weather influence	None
Dust influence	High
Salt, grit or sand influence	Low

35° configuration
Side elevation

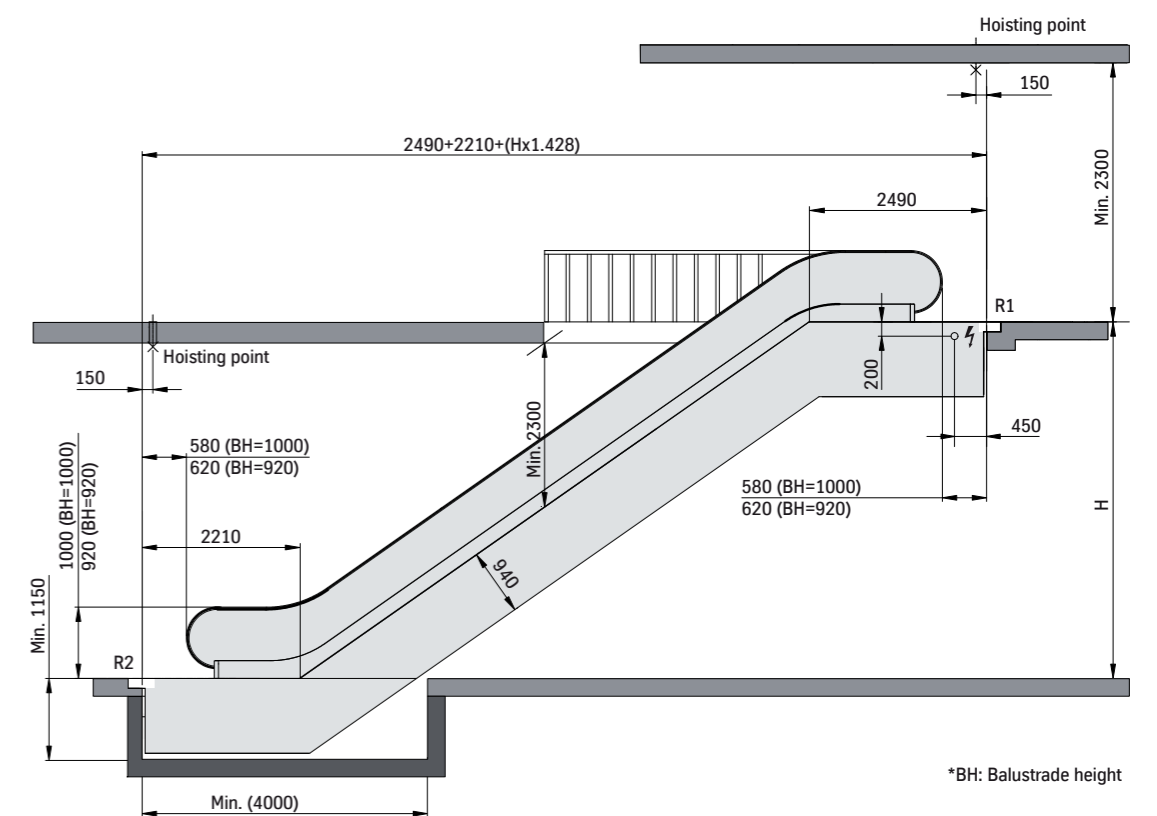

Plan view

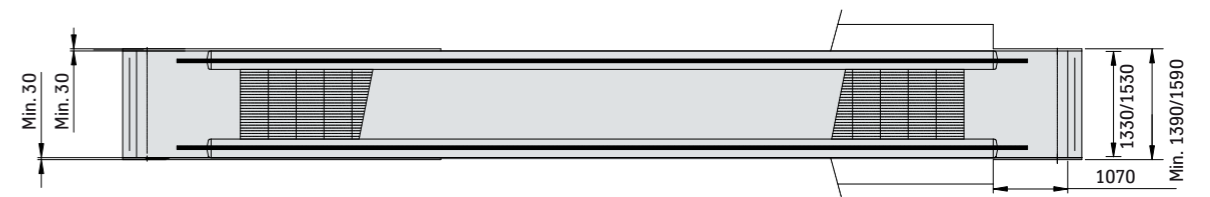

End support

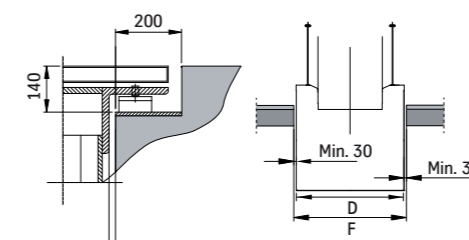

thyssenkrupp moves people – the future of urban mobility.

In 40 short years, we’ve become one of the world’s leading elevator companies with unique engineering capabilities, offering next-generation solutions like MULTI, the ropeless elevator, ACCEL, an accelerated people mover, and MAX, a cloud-based predictive maintenance service. Whether building a new state-of-the-art system or optimizing and modernizing existing ones, our solutions deliver crucial energy and time efficiencies, helping to address the challenges of urbanization and transform cities into the best places to live.

Customers in **150** countries

Over 900 sales and service locations

Sales of over **€ 7.2** billion

50,000+ employees

Figures for our Elevator Technology business

A trusted partner

We support our customers throughout their project lifecycle, from the design to the end-of-life phase. Every step of the way, we strive to fully understand their needs and consistently deliver the safest, highest quality passenger transportation solutions, maintenance and modernization packages.

Through our internal technical support function, ITS (International Technical Services), thyssenkrupp trains its service technicians in a multibrand portfolio, enabling them to successfully service more than 1.2 million units under maintenance.

thyssenkrupp – the diversified industrial group

engineering.tomorrow.together – three words that describe who we are, what we do, and how we do it. Driven by global megatrends such as urbanization and the need for efficient use of environmental resources, our global community of more than 150,000 colleagues works together with our customers to harness our engineering expertise and strive for technological and business solutions that satisfy the demand for “more” in a “better” way.

Find out more: www.thyssenkrupp.com



One World Trade Center



Makkah Clock Tower / Source © SL Rasch

We provide smart and innovative products for a wide variety of applications:

- Passenger and freight elevators
- Escalators and moving walks
- Passenger boarding bridges
- Stair and platform lifts
- Customized service and modernization solutions



thyssenkrupp Quartier



Mercedes Benz