



EVOLUTION 200

Low- to mid-rise elevators



ABOVE AND BEYOND

Setting our sights on the future by utilizing modernization, we continue to be consistent in supplying high-quality products and services.

In August 2020, TK Elevator became a standalone elevator company through its sale by thyssenkrupp AG. Now solely focusing on elevators, we are moving forward with state-of-the-art tools and technology to reinvent prior transportation expectations. In order to challenge the limits of what was previously possible -- we introduce evolution -- our advanced, pre-engineered low- to mid-rise elevators.





CONTENTS

02

Above and beyond

Choose evolution 200 04

We design solutions for everyone 06

08

Mobility made easier 08

12

AGILE 12

13

MAX 13

14

Simple yet sophisticated 14

Steel Shell Design 15

Finishes 16

Applied Panel 17

Fixtures and returns 18

Cab accessory options 19

Door configurations 20

Entrance options 21

22

Planning

Passenger elevators 23

Service elevators 24

Evolution hoistway efficiency 25

Controller closets 25

Technical specifications 26

CHOOSE EVOLUTION 200

**An elevator that defines
innovation and goes
beyond the essentials.**

The world is rapidly growing. New ideas, innovations, and modernizations are rising to make the future safer and more efficient. When you're deciding on an elevator, you'll want the most dependable option.

Choosing the evolution 200 will be the easiest decision you've ever made. This elevator provides everything you need to keep your building moving safely with the technology of tomorrow.









We design solutions for everyone

We've designed an MRL elevator for up to 35 stops that's not only competitive, it's better.

You've got options and flexibility.

 **You don't have to sacrifice size for speed.**
You can have a 5000-pound (2268 kg) capacity elevator and still go 600 feet per minute (3.0 meters per second).

 **Extra safe elevator without paying extra.**
Our auto-rescue feature comes standard and prevents passengers from being trapped during a power outage.

 **Controller that fits into an 8 1/2-inch (216 mm) door jamb.**
There's no need for a control closet, which means one less thing to build, unless your jurisdiction requires a machine room.

 **You don't have to waste space.**
Using belts means our equipment uses a small hoisting machine requiring less space.

 **You get a super quiet ride.**
Our design makes it the industry's quietest, inside and out.

 **You get a hassle-free installation.**
No crane needed and everything fits into the hoistway.

 **You can gain LEED credits.**
Material and Resources credits, that is. We have material transparency certifications, declarations plus a regenerative drive that saves energy.

Architects

Stop stressing over elevator space. We've got you covered. When we say machine room-less, we mean it. Literally everything fits into the hoistway.

- It has belts, so major components like the machine and sheaves take up less space. You've got more room to design that masterpiece.
- Our elevator is supported from the guide rails.
- The controller is built right into the door jamb. So, don't worry about building that controller closet or machine room.
- Your lobby design doesn't have to stop at the elevator door.
- evolution 200 has various design choices for your cabs.
- Each pre-engineered cab design meets ASME A17.1 code.
- If those don't work, our 200 model lets you choose custom finishes, even heavy ones.



Building owners

Just because it's for low- to mid-rise buildings does not mean you can't get high-quality features.

- This elevator uses belts, not ropes. It's quiet and doesn't have jerky stops and starts.
- Belts are better. They weigh less than steel ropes, so the major components don't have to move as much weight, making them smaller and lighter.
- Shhh... this elevator car is super quiet, just 50 decibels — like a conversation at home after the kids are in bed.
- It's all about suspension and a finely-tuned electronic drive that gives you a smooth, smooth ride.

Contractors

You don't need to dedicate so much time to getting your elevators installed. And since time is money, you can put your checkbook away. evolution has a simple design for a simple installation. So go ahead and accelerate your schedule.

- Everything you need arrives at the job site in one sequentially packaged shipment.
- It's an MRL. It truly is. All the components fit in the hoistway. The controller is in the door jamb at the top landing.
- It's designed so you can install the roof early. We won't need to use your crane.
- You don't need remote runs of wires from the elevator machine to the controller.
- The elevator supports itself. No need for overhead support steel.



MOBILITY MADE EASIER

evolution 200 combines
simplicity and ease of service.

Unlike yesterday's elevators, we've simplified the installation process. You no longer need a crane and can install the roof early — no more waiting on us. Everything arrives at the job site in one shipment, with sequential packaging.

When we're not onsite, your elevator is constantly being monitored by MAX, the elevator industry's first cloud- and IoT-based digital predictive maintenance solution. Because of MAX, you'll receive smarter service and maintenance along with transparency and peace of mind.

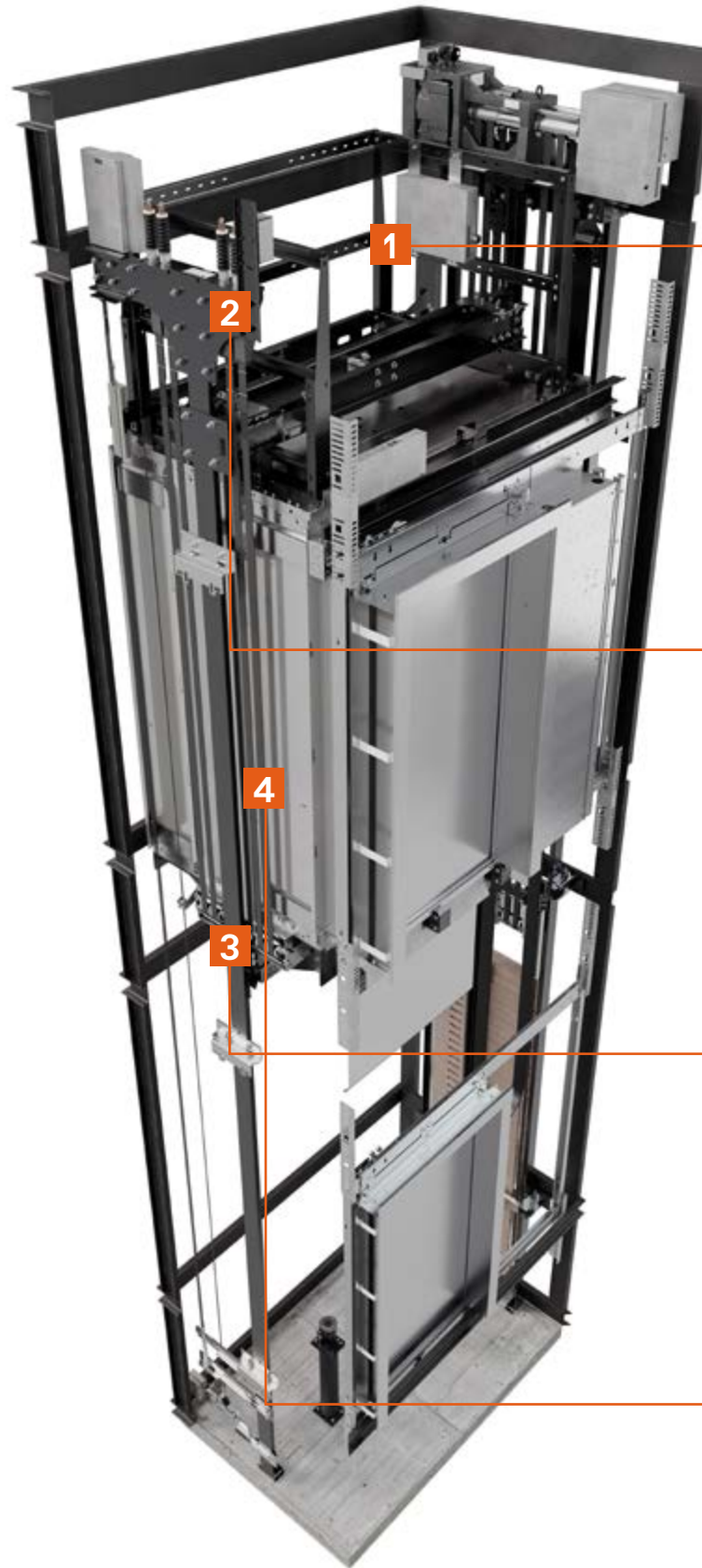

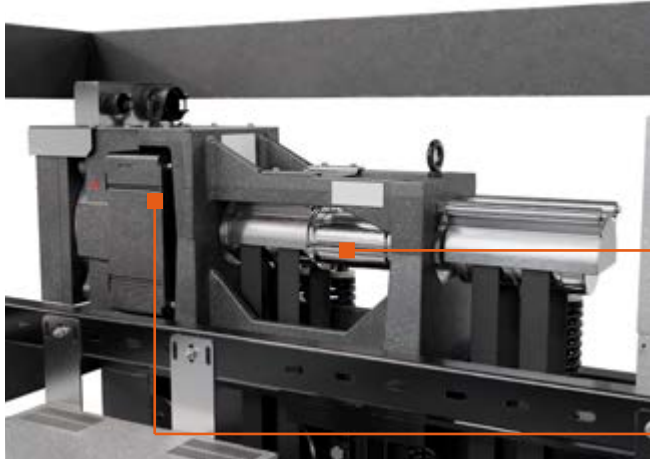

1 Machines

Our machines transport elevators up to 600 feet per minute (or 3.0 meters per second) with evolution 200. There's no machine room, so you have more leasable building space.

Sheaves

The smaller sheaves in evolution have a tighter turning radius, allowing for a compact motor that takes up less overhead space.

Permanent magnet gearless system

Improves ride quality while increasing energy efficiency.



2 Rail-supported

evolution 200 is supported by its rails rather than your building. That means your installation requires less coordination between trades.



3 Underslung design

Helps evolution offer a smaller hoistway and reduced overhead space.



4 Belts

Belts have a longer life span than ropes. They also provide a quieter and smoother ride. Belts consist of fourteen internal steel cords encased in FT1 fire-rated polyurethane material, making the suspension means lighter than steel cables.

Efficiency and high-performance

evolution 200 is built with robust and high-quality components. The powerful yet compact motor transports passengers to their destinations up to 25 percent faster than competitors.

LED lights come standard, are energy-efficient, and automatically turn off when the elevator isn't in use.

Controller

Fits into a tiny 8½-inch (216 mm) door jamb and is fully digital. This saves space and helps reduce elevator noise.

Regenerative drive

Captures unused energy generated by the elevator and feeds it back into your building grid. It's more compact, easier to maintain and replaces motor and brake contractors with SIL3 solid-state devices for a quieter and more reliable drive.

Auto-rescue

In a power outage, passengers are automatically transported to the next available floor and doors open so they can get out.



evolution 200 travels up to 25% faster than competitors.



Universal door operator

Malfunctioning doors are the leading cause of elevator service calls. This new technology provides door reliability as well as quick and smooth door operation.



Absolute positioning system

Precisely measures your elevator's speed and positioning. This promotes accurate floor stopping, so floors are level and passengers are safe.

ENHANCE EFFICIENCY. REDUCE TRAFFIC.

Upgrade your elevators — and your building — by adding AGILE. Our Destination Dispatch solution combines four intelligent elements that improve elevator performance, enhance passenger experiences, reduce building traffic and increase your building security.

AGILE groups passengers together who are traveling to similar floors, resulting in 25 percent faster travel time. The technology also lets you make data-driven decisions to manage your elevator performance.

It integrates with your building's security system or can function as a standalone system. You're also set for future upgrade opportunities with built-in cameras and RFID card readers.

AGILE touchscreen kiosks direct elevator passengers to their destination. They have clear, concise graphics, making them simple to use. The kiosks can be easily customized using your company's background and logos — or choose from pre-loaded options. AGILE is only available on evolution 200 control systems. Contact your local sales representative for further details.



With a wide variety of design options to choose from, you can create a unique look that reflects your building and tenants.

MAXIMIZE YOUR UPTIME



Get smarter service and less downtime with MAX

Combining the power of big data and machine learning, MAX continuously collects data about your elevator's components and systems, and sends it to the cloud. The data is analyzed, and algorithms determine when your elevator will require maintenance from our technicians. We call this predictive maintenance.

It's revolutionary and can reduce your elevator downtime by up to 50 percent. We're continuously improving MAX, so you can expect its benefits to get bigger and better over time.

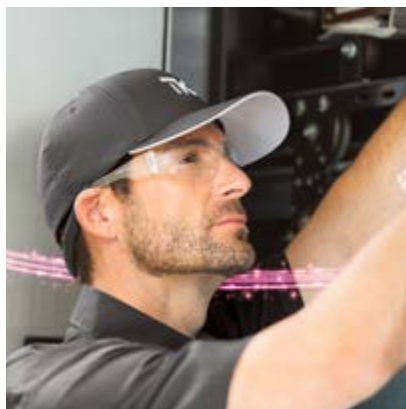

Repairs are completed in less time.



MAX sends equipment diagnostic analysis.



MAX works onsite 24/7/365.



SIMPLE YET SOPHISTICATED

Our cab and finish options let you personalize your evolution 200 elevator interior. Just like you want to.

Pictured above: Graystone plastic laminate vertical applied panels with downlight ceiling.

Steel Shell Design

Standard cab designs



Steel shell wall design

Clean and modern flat cab interior designs convey quality. Our durable formed steel shell cab is available in a variety of powder coat options in evolution 200, or can be upgraded to stainless steel.

Finishes

Plastic laminates

Woods

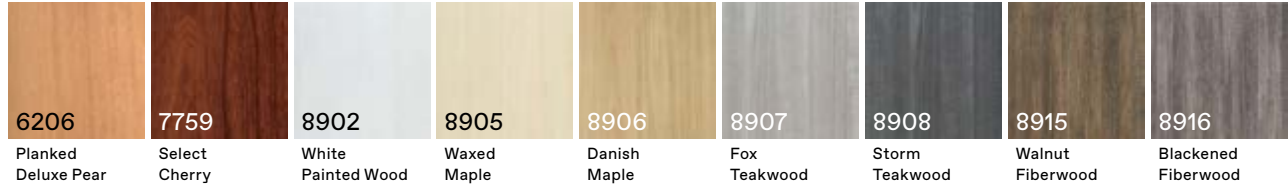

Solids

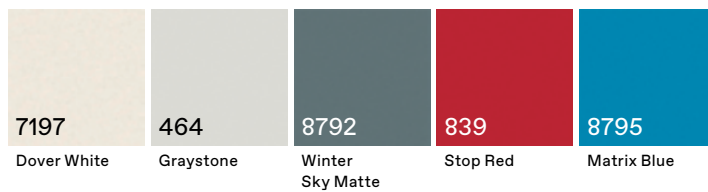

Patterns

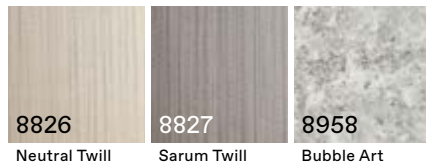

Powder Coats



Metals

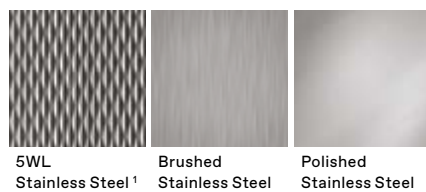

¹ Limited application. Contact your local representative for details.

 Colors may vary. We recommend examining a large color selector sheet before making a selection.

Applied panel

Upgraded cab



Steel shell wall with removable panel design

Mix beauty and practicality with this decorative and durable cab. The panel design is constructed with a high-quality steel shell and vertical raised panels made with a core of urea formaldehyde-free wood.

Fixtures

Traditional fixtures

Product details

- Faceplates in brushed or polished stainless steel
- Position indicator displays car location



Combo hall lantern and position indicator with directional arrows



Intermediate hall lantern with arrows



Intermediate hall station



Intermediate hall station with fire services devices



Push button available in blue, white, red and green LED lighting



Car operating panel

Vandal-resistant fixtures

Product details

- Faceplates in brushed or polished stainless steel
- Extra level of protection in challenging environments
- Pry-resistant hall jamb symbols and buttons



Combo hall lantern and position indicator with directional arrows



Intermediate hall lantern with arrows



Terminal hall station



Intermediate hall station with fire services devices



Push button available in red, blue, white and green LED lighting



Car operating panel

Fixtures shown above are for representation only. Your project-specific application may vary.

Cab accessory options

Ceilings

Suspended

White translucent diffusers for LED lighting are available with ceiling frames in a powder coat or stainless steel finish.



Downlight

Metal pan downlight ceiling features LED lighting with six or nine lights (based on cab size). Lights are mounted in your choice of powder coat or stainless steel ceiling panels.



Handrails

Cylindrical

1 1/2-inch (38 mm) cylindrical handrail is a continuous metal form with ends turned toward the wall. Comes in stainless steel finish.



Flat bar

Metal bar handrail is available in 1/4" (6 mm) thickness and 2" (51 mm), 4" (102 mm) or 6" (152 mm) widths. Comes in stainless steel finish.



Sills

Our cab sill finishes allow you to match your sills to any other design component inside the cab.



2

Braille plates

Option 1: Resin braille plate

Option 2: Surface mount cast braille plate

Option 3: Flush (inlaid) mount cast braille plate

⚠ Illustrations vary based on configurations.

Door configurations

Door orientation options offer a range of benefits to accommodate different project needs.

One-speed The most economical door offering, available with either right- or left-hand opening. (right-hand shown)

Two-speed Provides a wider opening without compromising door cycling time. Two doors move in the same direction, one sliding faster than the other. Available with either right- or left-hand opening. (right-hand shown)

Center opening Best for high-traffic buildings. Permits the quickest entry and exit, improving elevator service while giving an attractive, symmetrical appearance.

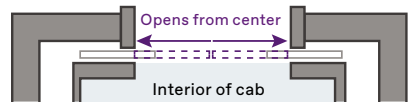
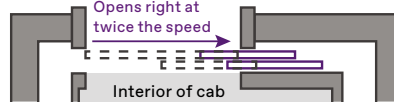
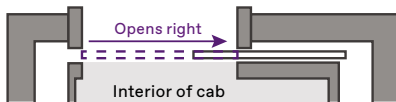
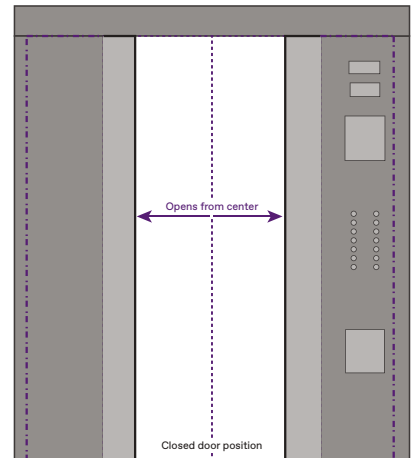
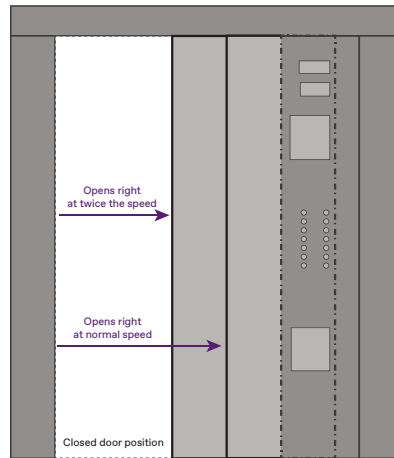
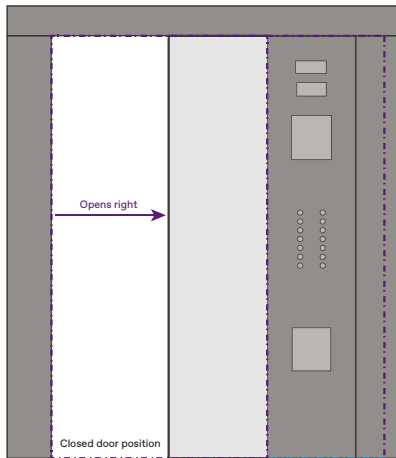

Front returns



Wrap-around returns
This return features a hinged car operating panel and separate filler panel. Comes standard.

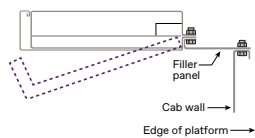

Column returns
This return features a hinged car operating panel secured to the filler panel and aligned vertically with the column.

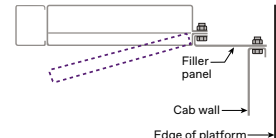

Front returns include the car station, return panel, signal fixtures and head jamb. Images above represent return types in brushed stainless steel.

Entrance options

The entrance frame and door are supplied by TK Elevator. You'll choose from powder coats or metal finishes.

Hoistway entrance frame

Face of frame is a minimum of two inches (51 mm). Increases to three inches (76 mm) on controller landing.

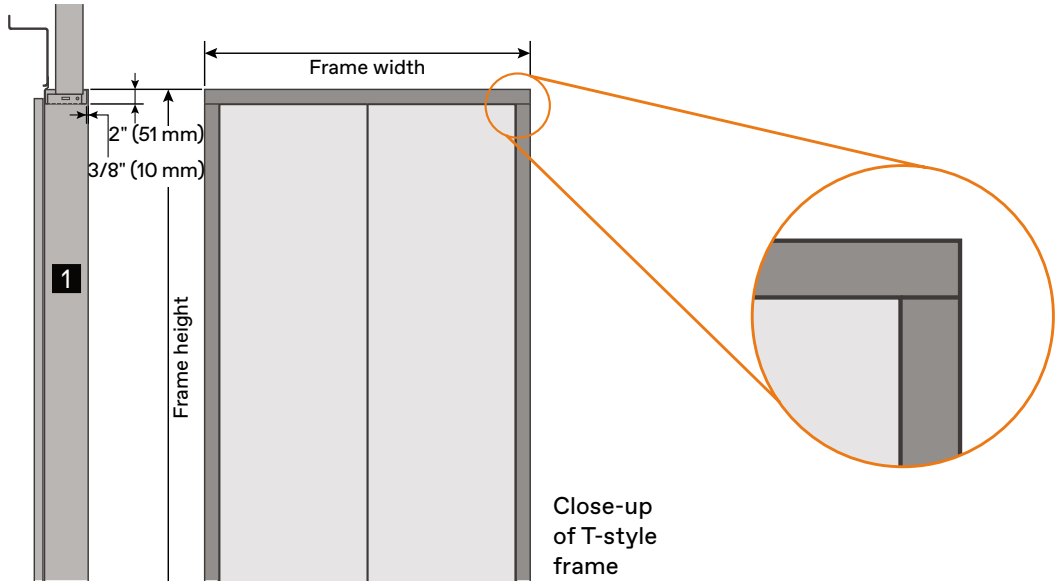

Hoistway and door entrance finishes

Typically, the entrance frame would match the door selection, but nothing says you have to. Choose from any powder coat color or metal finish.



Powder coat finish
T-style entrance frame in Blue Patina powder coat.



Metal finish
T-style entrance frame in Brushed Stainless Steel.

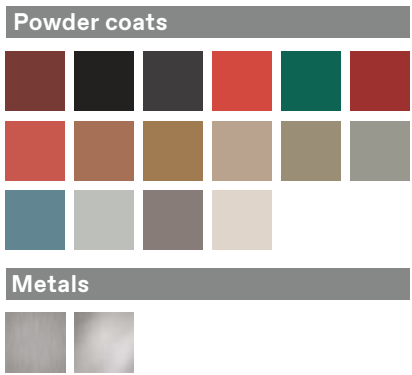

PLANNING

At a glance



Travel
350'-0"
(106 680 mm)



Technology
Gearless traction



Type
Self supported



Max stops
35



Speed
200 - 600 fpm
(1.0 - 3.0 m/s)



Capacity
2100 - 5000 lbs
(953 - 2268 kg)



Fit
Machine room-less



Max openings
35 (front only)
70 (front and rear)

evolution 200

Passenger elevators

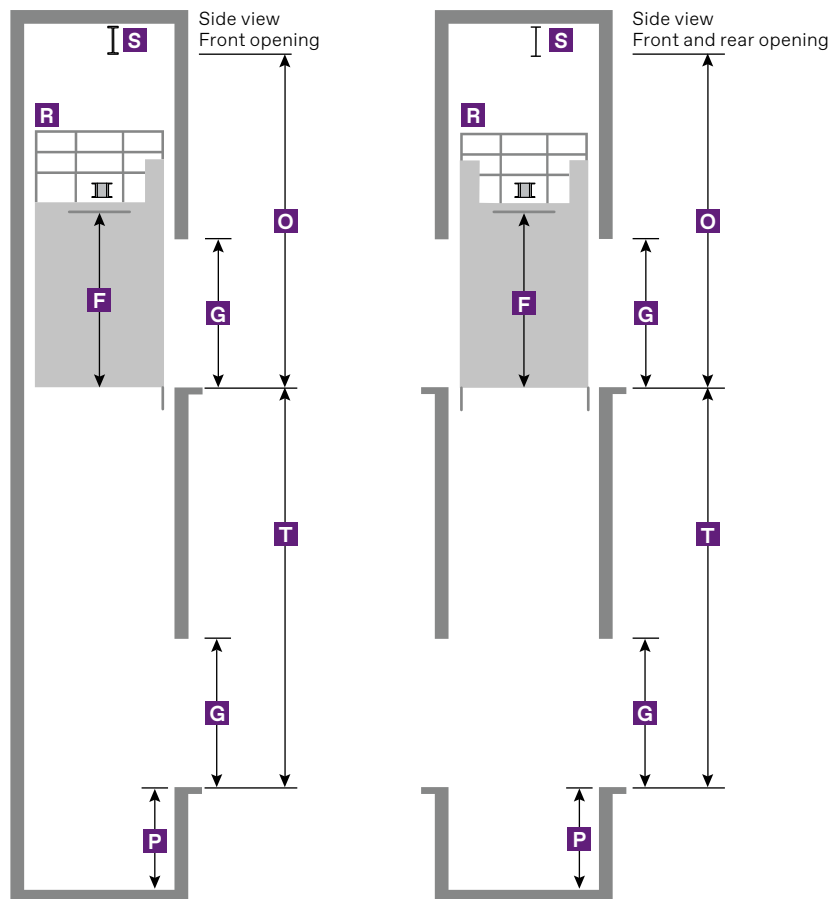

One-speed center opening doors

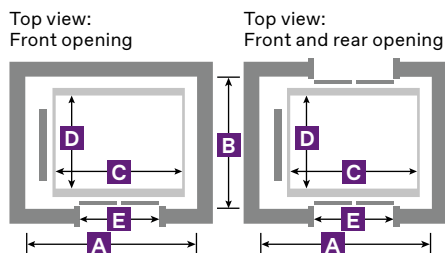

One-speed side opening doors

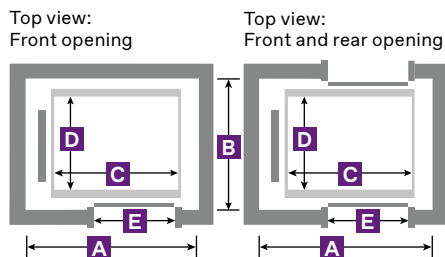

- A** Hoistway width
- B** Hoistway depth
- C** Inside clear width
- D** Inside clear depth
- E** Door clear width
- F** Inside clear height
- G** Door clear height
- O** Minimum overhead
- P** Minimum pit depth
- R** Car top railing
- S** Safety beam
- T** Travel

F Inside clear height: 7'-4" (2235 mm)^{1,2}

G Door clear height: 7'-0" (2134 mm)¹⁰

S 8" (203 mm) safety beam 2" (51 mm) clear above required capable of holding 7500 lbs (3402 kg)⁷

O Minimum overhead^{6,7}
 200 fpm (1.0 m/s): 12'-8" (3861 mm)
 350 fpm (1.8 m/s): 13'-4" (4064 mm)
 500 fpm (2.5 m/s): 13'-11" (4242 mm)
 600 fpm (3.0 m/s): 15'-0" (4572 mm)

P Minimum pit depth^{9,12}
 200 fpm (1.0 m/s): 5'-0" (1524 mm)
 350 fpm (1.8 m/s): 5'-6" (1676 mm)
 500 fpm (2.5 m/s): 6'-6" (1981 mm)
 600 fpm (3.0 m/s): 7'-2" (2184 mm)

All dimensions are based on a standard single hoistway in non-seismic installations.

Contact your local representative for various code or jurisdictional exceptions. Also contact them if same hand door configurations or other alterations are required.

See endnotes on page 26.

Passenger elevators

Capacity lbs (kg)	Hoistway ⁴ A x B - ft in (mm)	Front/rear	Inside clear ⁸ C x D - ft in (mm)	Door type	Door width E - ft in (mm)
2100 ^{3,13} (953) ^{3,13}	7'-6" x 5'-9" (2286 x 1753)	F	5'-8" x 4'-3 ³ / ₈ " (1727 x 1295)	One-speed	3'-0" (914)
2500 (1134)	8'-6" x 5'-9" (2591 x 1753)	F	6'-8" x 4'-3 ³ / ₈ " (2032 x 1305)	One-speed	3'-6" (1067)
2500 ^{5,25} (1134) ^{5,25}	8'-6" x 6'-8 ³ / ₈ " (2591 x 2042)	F/R	6'-8" x 4'-3 ³ / ₈ " (2032 x 1318)	One-speed	3'-6" (1067)
3000 ⁵ (1361) ⁵	8'-6" x 6'-3" (2591 x 1905)	F	6'-8" x 4'-9" (2032 x 1448)	One-speed	3'-6" (1067)
3000 ^{5,25} (1361) ^{5,25}	8'-6" x 7'-2" (2591 x 2184)	F/R	6'-8" x 4'-9 ¹ / ₂ " (2032 x 1461)	One-speed	3'-6" (1067)
3500 ⁵ (1588) ⁵	8'-6" x 6'-11" (2591 x 2108)	F	6'-8" x 5'-5" (2032 x 1651)	One-speed	3'-6" (1067)
3500 ^{5,25} (1588) ^{5,25}	8'-6" x 7'-10" (2591 x 2388)	F/R	6'-8" x 5'-5 ¹ / ₂ " (2032 x 1664)	One-speed	3'-6" (1067)
4000 ⁵ (1814) ⁵	9'-6" x 6'-11" (2896 x 2108)	F	7'-8" x 5'-5" (2337 x 1651)	One-speed	3'-6"/4'-0" (1067/1219)
4000 ⁵ (1814) ⁵	9'-6" x 7'-10" (2896 x 2388)	F/R	7'-8" x 5'-5 ¹ / ₂ " (2337 x 1664)	One-speed	3'-6"/4'-0" (1067/1219)

evolution 200

Service elevators

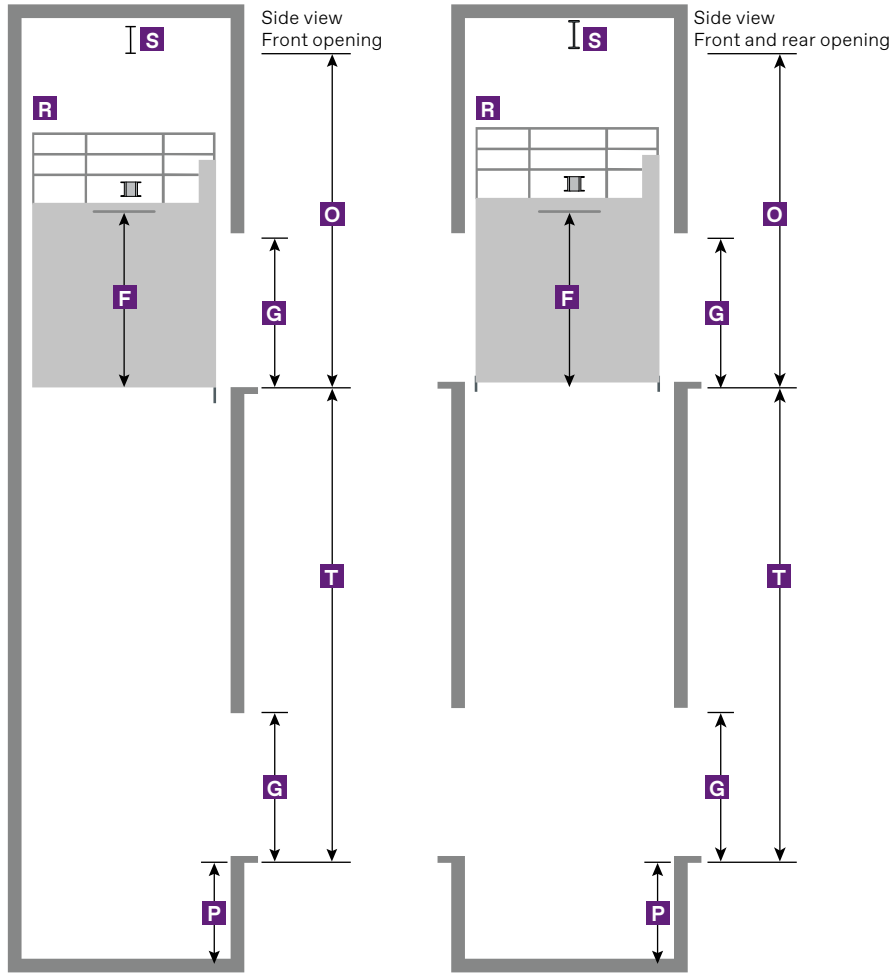

- A** Hoistway width
- B** Hoistway depth
- C** Inside clear width
- D** Inside clear depth
- E** Door clear width
- F** Inside clear height
- G** Door clear height
- O** Minimum overhead
- P** Minimum pit depth
- R** Car top railing
- S** Safety beam
- T** Travel

Two-speed side opening doors

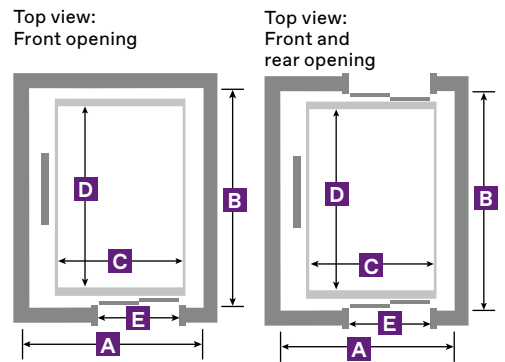

- F** Inside clear height: 7'-4" (2235 mm)^{1,2}
- G** Door clear height: 7'-0" (2134 mm)¹⁰
- S** 8" (203 mm) safety beam
2" (610 mm) clear above
required capable of holding
7500 lbs (3402 kg)⁷

- O** Minimum overhead^{6,7}
200 fpm (1.0 m/s): 12'-8" (3861 mm)
350 fpm (1.8 m/s): 13'-4" (4064 mm)
500 fpm (2.5 m/s): 13'-11" (4242 mm)
600 fpm (3.0 m/s): 15'-0" (4572 mm)

- P** Minimum pit depth⁹
200 fpm (1.0 m/s): 5'-0" (1524 mm)
350 fpm (1.8 m/s): 5'-6" (1676 mm)
500 fpm (2.5 m/s): 6'-6" (1981 mm)
600 fpm (3.0 m/s): 7'-2" (2184 mm)

All dimensions are based on a standard single hoistway in non-seismic installations.

Contact your local representative for various code or jurisdictional exceptions. Also contact them if same hand door configurations or other alterations are required.

See endnotes on page 26.

Service elevators

Capacity lbs (kg)	Hoistway ^{4,11} A x B - ft in (mm)	Front/ rear	Inside clear ⁸ C x D - ft in (mm)	Door type	Door width ¹¹ E - ft in (mm)
4500 (2041)	7'-6" x 9'-6½" (2286 x 2908)	F	5'-8" x 7'-9½" (1727 x 2375)	Two-speed	4'-0"/4'-6" (1219 /1372)
4500 ²⁵ (2041) ²⁵	7'-6" x 10'-8½" (2286 x 3264)	F/R	5'-8" x 7'-10" (1727 x 2388)	Two-speed	4'-0"/4'-6" (1219 /1372)
5000 (2268)	7'-6" x 10'-2" (2286 x 3099)	F	5'-8" x 8'-5" (1727 x 2565)	Two-speed	4'-0"/4'-6" (1219 /1372)
5000 ²⁵ (2268) ²⁵	7'-6" x 11'-4" (2286 x 3454)	F/R	5'-8" x 8'-5½" (1727 x 2578)	Two-speed	4'-0"/4'-6" (1219 /1372)
5000H (2268H)	7'-6" x 10'-9" (2286 x 3277)	F	5'-8" x 9'-0" (1727 x 2743)	Two-speed	4'-0"/4'-6" (1219 /1372)
5000H ²⁵ (2268H) ²⁵	7'-6" x 11'-11" (2286 x 3632)	F/R	5'-8" x 9'-0½" (1727 x 2756)	Two-speed	4'-0"/4'-6" (1219 /1372)

evolution hoistway efficiency

Everything fits into the hoistway, giving you more leasable building space.

Reduced hoistway width, depth and height are due to the compact machine with small components and underslung design. This results in a smaller building footprint.

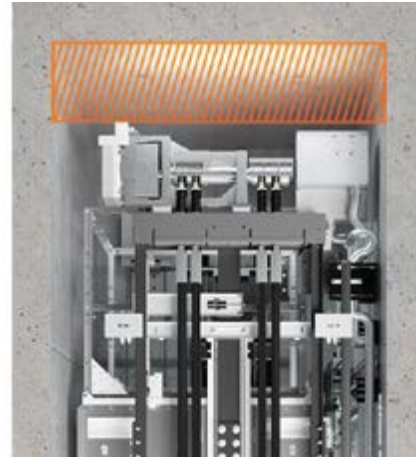

evolution 200 controller closets

The features of your evolution system determine the controller closet you'll need.

Controller closets includes room for controller, disconnect and resistor boxes. The most desirable controller closet location is on the top floor served, adjacent to the elevator hoistway.

At an additional cost, it may be located remotely, but the traveling cable must be no longer than 150 feet (45 720 mm) from the machine to controller.

Some jurisdictions require controller closets to be full-body entry; small spaces or closets may not be acceptable. Check with your TK Elevator representative.

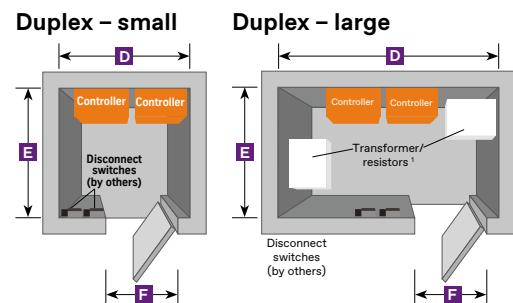
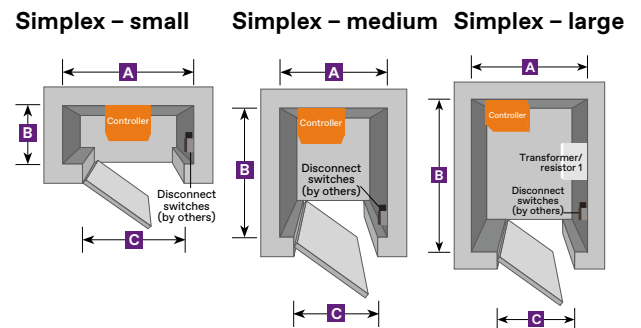

Simplex ²³			Duplex ^{23, 24}			
Size	A - ft in (mm)	B - ft in (mm)	C - ft in (mm)	D - ft in (mm)	E - ft in (mm)	F - ft in (mm)
Small	4'-6" (1372)	2'-0" (610)	3'-0" (914)	5'-6" (1676)	5'-5" (1651)	3'-0" (914)
Medium	3'-10" (1168)	4'-7" (1397)	3'-0" (914)	9'-2" (2794)	5'-5" (1651)	3'-0" (914)
Large	4'-6" (1372)	5'-11" (1803)	3'-6" (1067)			

See endnotes on page 26.

Technical specifications

Power characteristics	Low- or high-voltage power requirement is based on machine size, car capacity and number of belts. 480 volts, 3 phase, 60 hertz (high voltage) is used on six belt systems with speed of 200 fpm (1.0m/s) or greater and 3500-pound (1588 kg) cars or greater, but high voltage may be required on some four belt systems if the larger machine is used. With a 1587.5 kg car or less, using four belts with speed of 200 fpm (1.0 m/s), the lower voltage option is available. Isolation transformer may be required on jobs with less than 480 VAC, 3 phase or if building supply is 575 VAC. Transformer must be located within 125 feet (38 100 mm) of controller. Transformer installed by TK Elevator but wiring installed by others.
Solid state brake controls	Dual braking system (main and emergency.) Contactor-less components for emergency and normal brakes as well as motor that reduces noise
Number of belts	Four or six, based on car capacity, car weight requirements and travel.
Suspension means	Flat belt: 14 internal steel cords encased in FT1 fire rated PU material
Belt monitoring¹⁶	Monitored by residual life span, traction loss detection device, belt member loss and a trip count
Machines	Permanent magnet gearless machine
Absolute position system	Sensor reads position data off of magnetic tape
Drive	Fully regenerative digital drive with automatic rescue included
Controller	TAC32T (in the wall or in optional control space if required by local jurisdictions, building constraints, and job-specific performance)
Door operator	Universal door operator
Car and counterweight guides	Car: Slide guides standard at 200 fpm (1.0 m/s); Roller guides standard at 350 - 600 fpm (1.8 - 3.0 m/s) Counterweight: Slide guides standard at 200 fpm (1.0 m/s)- 600 fpm (3.0 m/s) (counterweight-side only)
Governor	Remote resetting governor
Finished floor height	3/4" (19.1 mm) or 3/8"(9.5 mm) standard

Endnotes

Dimensional data shown is for non-seismic installations and complies with current ASME A17.1 and CSA B44 Safety Code for Elevators. Local codes may vary from the national codes. Consult your TK Elevator representative for details.

¹ Inside clear heights of 8'-4" (2540 mm) and 9'-4" (2743 mm) are also available on an evolution 200 model.

² Dimension shown is the distance between the suspended ceiling and a maximum 3/4" (19 mm) finished floor. If 3/8" (9.5 mm) finished floor, the inside clear height increases to 7'-4 3/8" (2245 mm).

³ 2100 lbs (953 kg) car capacity is not available with center opening doors.

⁴ For non-seismic installations, add 1" (25 mm) to hoistway width when travel exceeds 100' (38 480 mm). For seismic conditions, hoistway width must be increased based on overall travel. Add 2" (51 mm) if travel is 100' (30 480 mm) or less. If travel is greater than 100' (30 480 mm) but less than 250' (76 200 mm), add 3" (76 mm). If over 250' (76 200 mm) of travel, add 6" (152 mm). Contact your local TK Elevator representative to evaluate the building location to determine the seismic requirement.

⁵ To achieve IBC stretcher compliance, you can accommodate an 84" (2134 mm) ambulance stretcher in car capacities of 2500, 3000, 3500, and 4000 lbs (1134, 1361, 1588, and 1814 kg) with 3'-6" (914 mm) side opening doors. However, this is dependent on cab and door configurations. We also offer 4500 and 5000 lbs (2041 and 2268 kg) car capacities with no configuration restrictions. Contact your TK Elevator representative for specific cab and door configurations.

⁶ For areas enforcing ASME A17.1 2010 code or greater, the minimum overhead requirement is the same for simplex/multicar/seismic/non-seismic. For areas enforcing pre-2010 ASME A17.1 code and speed is equal to 200 fpm (1.0 m/s), the minimum overhead is still the same, but if speed increases to 350 fpm (1.8 m/s) or more, the minimum overhead is greater than what is shown. Contact your local representative for overhead requirements.

⁷ Provided and installed by others, as directed by the local office. Minimum overhead is shown to the bottom of the safety beam.

⁸ Inside clear cab dimensions are based on maximum 1/2" (13 mm) applied wall panel for the evolution 200 product.

⁹ If occupied space below a pit is required, counterweight safeties come standard for evolution 200.

¹⁰ Door clear height of 8'-0" (2438 mm) and 9'-0" (2743 mm) are also available for taller cabs on evolution 200 but contact your local representative for additional details.

¹¹ For 54" (1372 mm) doors, hoistway width increases to 8'-3" (2515 mm) for non-seismic and seismic and are limited to the closet-mounted controller configuration only. For 48" (1219 mm) doors, see note 4.

¹² Minimum pit depth increases to 6'-6" (1981 mm) on a 4000 lbs (1814 kg) capacity car, going 350 fpm (1.8 m/s) when it exceeds 225' (68 580 mm) of travel because it needs a compensation wheel for balancing the car.

¹³ Front and rear openings are not available on 2100 lbs (953 kg) capacity cars.

¹⁴ Contractor-less components for brakes as well as motor that reduces noise.

¹⁵ Suspension belts consists of 14 internal steel cords encased in FT1 fire rated PU material.

¹⁶ Monitored by residual life span, traction loss detection device and belt member loss and a trip counter. Monitor remains a part of system indefinitely or until it is replaced or upgraded. Option; does not come standard.

¹⁷ Entrance mounted controllers cannot be grouped with closet applications.

¹⁸ A minimum of 2" (51 mm) of clearance between the top of the 8" (203 mm) safety beam and underside of hoistway ceiling is required.

¹⁹ Features in hall stations are limited to a combination of 3 devices.

²⁰ Powder coat colors from standard selection; no special paints.

²¹ Emergency evacuation to the next landing. (It is automatic and load dependent).

²² 5- or 10-car supported. With jamb-mounted controllers, mounting location and provisions will have to be determined.

²³ Controller closet temperature range 32°F minimum, 104°F maximum. 10-95% non-condensing relative humidity.

²⁴ May also use two separate closets.

²⁵ On front and rear door opening cars that are configured with same hand doors (catty-corner), additional hoistway width is required. For 2500, 3000, 3500 lbs (1134, 1361, 1588 kg) capacity cars with 42" (1067 mm) doors and 4500, 5000 lbs (2041, 2268 kg) cars with 48" (1219 mm) doors, hoistway width must be increased additionally by 2" (51 mm). For 4500, 5000 lbs (2041, 2268 kg) cars with 54" (1372 mm) doors, hoistway width must be increased additionally by 11" (279 mm).

Illustrations and images in this brochure may differ from the installed product. Consult your local representative for more information.

YOUR INNOVATION PARTNER

elevators and escalators under maintenance

countries of customers

1,500,000 100+

employees

50,000+

service available for customers

locations

24/7 1,000+

service technicians

25,000+

TK Elevator (Canada) Limited
2075 Kennedy Rd., Suite 600,
Scarborough (Ontario) M1T 3V3
P: 416 291-2000
www.tkelevator.com/ca-en



All illustrations and specifications are based on information in effect at time of publication approval.
TK Elevator reserves the right to change specifications or design and to discontinue items without prior notice or obligation.
© 2023 TK Elevator (Canada) Limited. | CA License #C11-651371 | 28482-1 | evolution 200 elevator product brochure - Metric