

IWALK

The easier way.



IWALK. THE NEXT-GENERATION MOVING WALK

By revolutionising the way moving walks are designed, manufactured and installed, iwalk establishes a new industry benchmark. Its modular space-saving concept simplifies planning, integration and operation without compromising usability. For passengers traveling with luggage and carts, it offers greater safety and comfort. Fewer components and low energy consumption complete this sustainable product's ground-breaking engineering.

In escalator business since 1906

We were soon into the escalator business with our first model installed at a department store as long ago as 1906. 115 years of engineering excellence go into our velino, tugela and victoria models.

As diverse as they come

We build mobile escalators for boarding and disembarking aircraft, restaurant escalators with just one moving handrail for waiters with only one hand free, and suspended escalators that crisscross the open space of an atrium. You name it, we build it.

Remarkable locations

Our underwater installation at Shanghai's Ocean Aquarium ensures visitors enjoy spectacular sights. The One World Trade Center in New York has 12 of our escalators and 71 elevators. We also equipped the world's largest department store in Busan. Higher, bigger, better – escalators from TK Elevator.

Myth debunked

"Stand on the right, walk on the left" actually slows down passenger flow. Studies show that escalator capacity increases by about 30% if nobody walks. At TK Elevator, we know the escalator business like the back of our hand and it's this expertise that makes our new velino series so special.



Denver International Airport

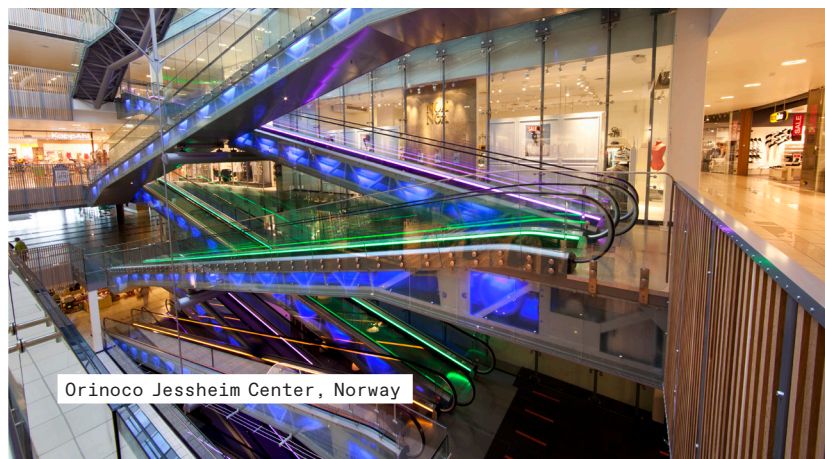

Orinoco Jessheim Center, Norway



CONTENTS

02
iwalk. The next-generation moving walk 02

04
A simple, reliable and attractive moving walk 04

06
Designed with quality in mind 06

08
A safe design for passengers 08

10
Energy savings through sustainable design 10

Dimensions and data 12

14
Our core principles 14

15
About us 15



A SIMPLE, RELIABLE AND ATTRACTIVE MOVING WALK

Moving walks matter.

Moving walks quickly transport people in high foot traffic settings, such as airports, train stations and shopping centers.

Until recently, installing new moving walks required extensive construction work and design challenges.

A combination of simplicity and reliability.

iwalk, TK Elevator's moving walk, combines increased interior space with minimized heights and outer dimensions. This means more passenger space. It's easy to install, with no crane or pit needed. The sophisticated design blends reliable performance and reduced energy consumption. Plus its compact enough for installation in buildings already in operation.



Planning is simple.

iwalk's reduced weight, lower static load requirements and modular structure allow last-minute design changes. It's also pitless, eliminating the need for extra civil work while making it suitable for sensitive surroundings. In fact, iwalk's oil-free system allows integration in protected environments, such as museums and outdoor spaces.



First impressions count.

We've made sure iwalk will add to your building's visual appeal. As an industry first, product designers helped us design this moving walk, letting it easily fit in with any architectural style.

Distinctive balustrade design.

iwalk features a slim-line balustrade that can be equipped with a specially-designed LED light channel. This distinctive design stands out in any setting.

Easier on the eye.

Our latest iwalk removes visible screws along the entire unit. This gives iwalk a streamlined, advanced look along with protection against vandalism. In addition, a higher proportion of glass increases iwalk's visual appeal.

Attractive lighting options.

iwalk offers a wide variety of lighting options. You can choose the lighting that best suits your surroundings, including under-handrail lighting that allows the handrail to float over the balustrade.

Outer decking replacement.

Should an iwalk be scratched in a high-traffic environment, the outer decking can be quickly and easily replaced.



DESIGNED WITH QUALITY IN MIND



We've integrated a range of innovative designs into iwalk. The outcome is a moving walk that's easy to plan and integrate into your building or outdoor location.

Easy integration.

iwalk consists of standardized modules, which are delivered in handy packages. This allows for faster delivery, even using air freight, plus easy integration into your job site. iwalk can also be the last unit incorporated after your building construction.

Easier on the building.

iwalk can be installed in a shallow pit, or sit on the surface of an existing floor. This reduces or eliminates the need for civil works. In combination with a 30% weight reduction compared to conventional designs, you'll have the opportunity to reduce floor thickness and enhance your building through higher ceilings.

Easier planning.

iwalk's modules are easily interchangeable or replaceable, making last-minute design changes possible. If you need to relocate your unit, iwalk makes it easy. All you need is a forklift. If your building lacks a conveyor system, iwalk allows infrastructure upgrades without additional civil works.

Easier to meet your needs.

iwalk is designed to meet the needs of its operator and users. In compliance with international codes, iwalk's standard 44-inch (1100 mm) pallet width is wide enough for large trolleys and carry-on luggage and still leaves room for other passing passengers. You won't need to upgrade to a wider, more expensive pallet band, and users have maximum convenience and safety. ADA-compliant access ramps are available upon request for the pitless design.



1

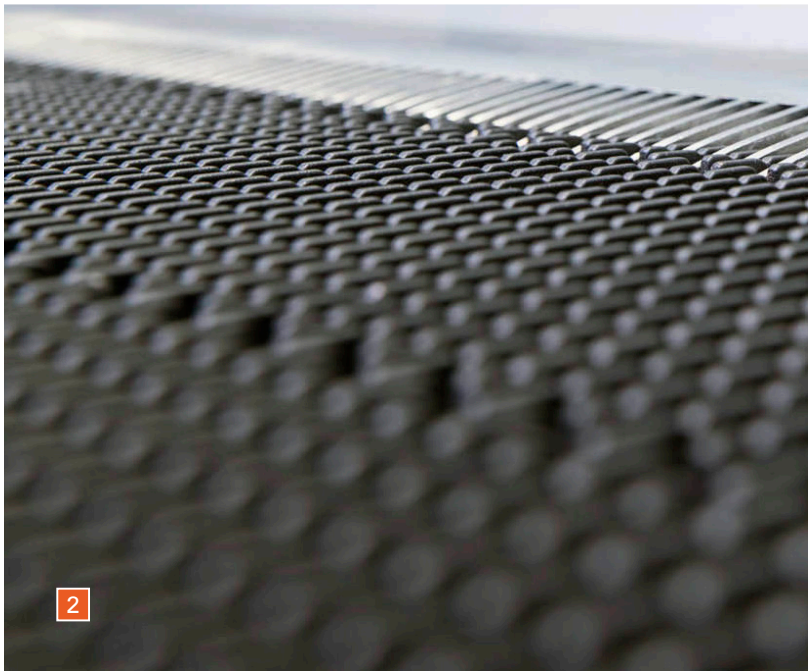

2



3

- 1 ADA compliant access ramps on an easy pitless installation
- 2 Materials reduced to a minimum: lighter appearance, easy handling
- 3 Self-contained interchangeable module design



A SAFE DESIGN FOR PASSENGERS

iwalk meets all safety code requirements. With more than 50 safety features – standard, optional and beyond – it's designed with rider safety in mind.

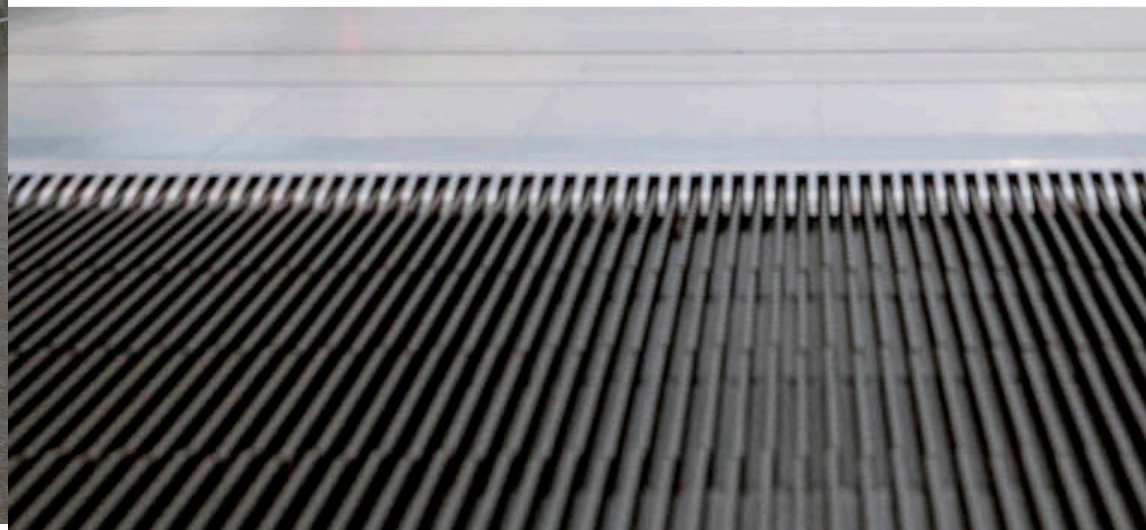

safety glass

1/2
inch thick (13 mm)

extended balustrade



comb height



Traffic lights.

Several traffic light options guide traffic and show approaching users if an iwalk is functional and running in the desired direction.

Full handrail guidance.

With an extended guidance handrail at the entrance and exit, iwalk supports users in entering and leaving. This is especially helpful for elderly and disabled individuals.

Flatter combs.

iwalk's comb segments are 5/16" (8 mm) above the pallet band, a reduction around 80% compared to conventional designs about 2" height (51 mm). These nearly-flat combs reduce stumbling risk, especially for individuals with limited mobility, using trolleys or carrying luggage.

Handrail inlet.

The unique handrail inlet with a two-door flap system eliminates rubber guards or brushes and reduces unintended activation. The wide opening is also a safety improvement.

ENERGY SAVINGS THROUGH SUSTAINABLE DESIGN

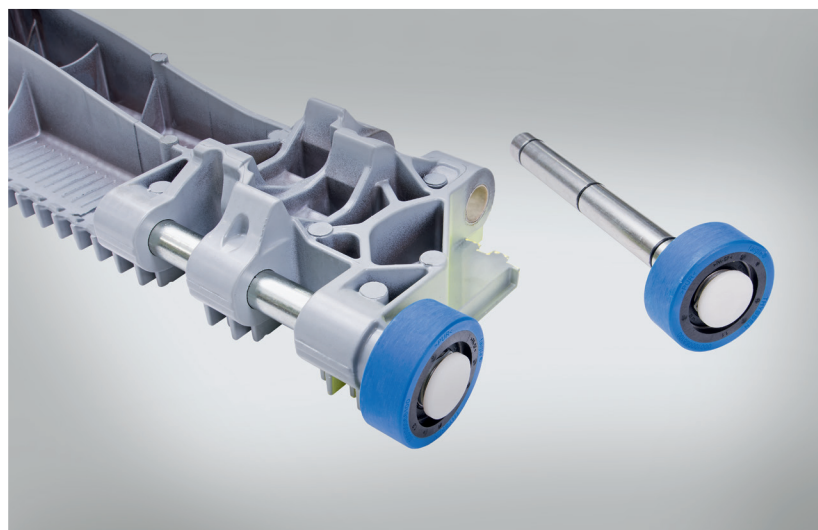
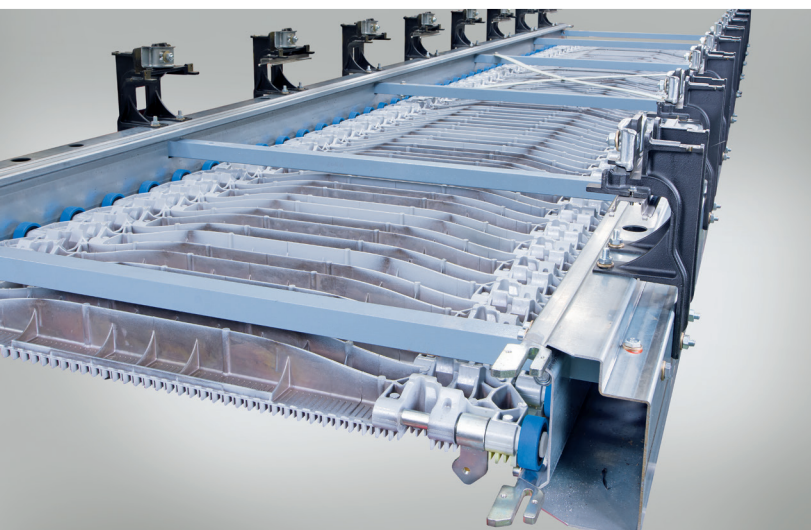



Sustainability is built into iwalk. We've reduced its weight, while adding energy-saving features.

Efficient energy performance.

Due to its reduced weight and energy-efficient features, such as the smart frequency converter, iwalk achieves A+++ ratings in accordance with ISO25745-3, the global standard for escalator and moving walk classification. This helps in getting your building certified.

Easier transportation.

A modular design and lighter construction reduce delivery trucks or containers compared to conventional moving walk designs. This lowers the CO² footprint during transportation.

Reduced environmental impact.

iwalk's new design concept reduces environmental impact by up to 20%.

Simplified maintenance.

The innovative pallet construction and power transmission system eliminates the need for chains and lubrication. As a result, there are less maintenance requirements and reduced environmental impact.

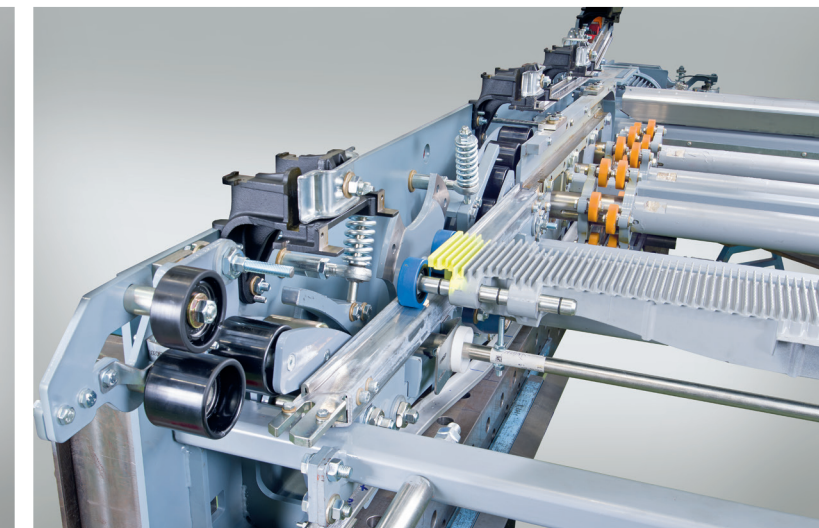

Dimensions and data

Shallow pit side view

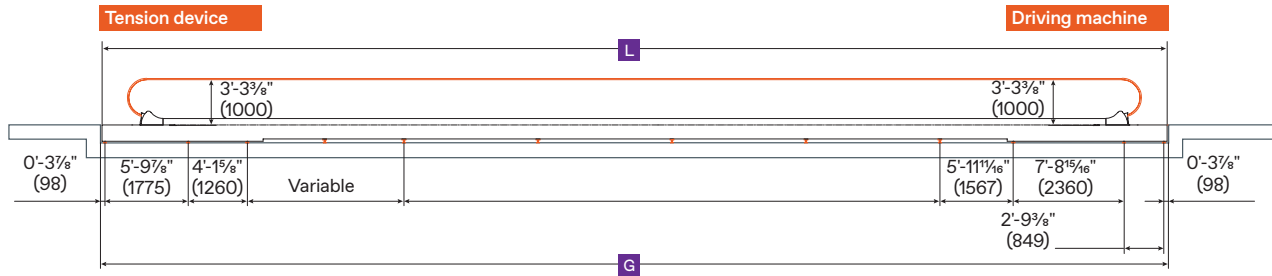

Shallow pit top view

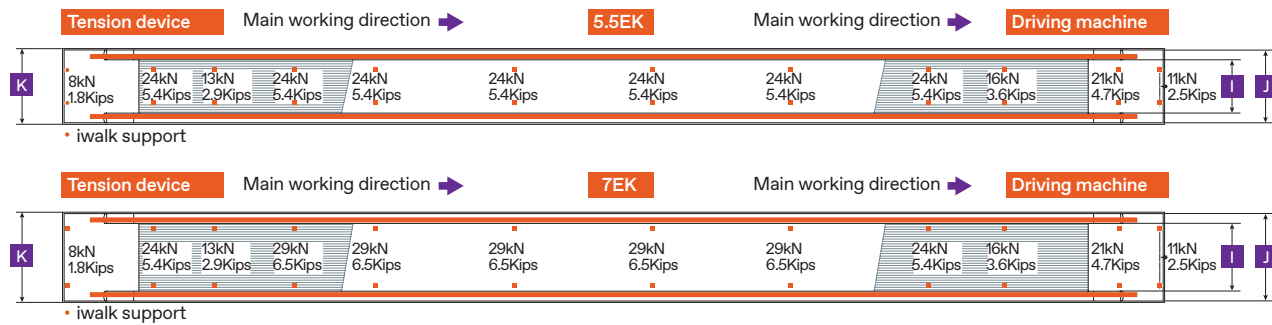

Shallow pit supports

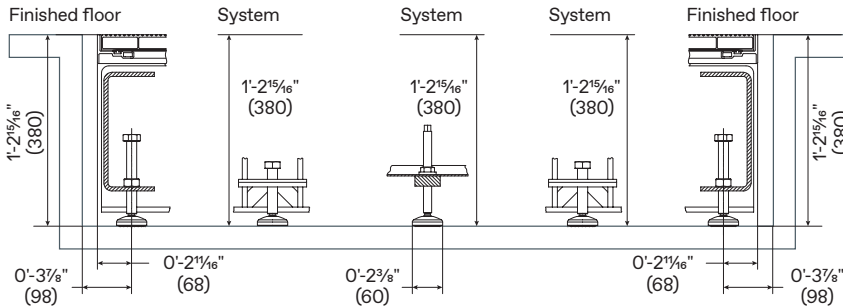

Shallow pit front view

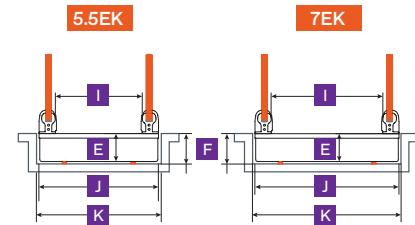

iwalk moving walks			
Max capacity (people/hour)	6000 at 100 fpm (0.5 m/s) 7300 at 120 fpm (0.65 m/s)	Operating speed	100 fpm (0.5 m/s) and 120 fpm (0.65 m/s)
Inclination	0° – 3°	Balustrade height	3'-3 3/8" (1000 mm)
Configuration	Shallow pit Pitless	Aesthetic lights	Balustrade Skirt
Application	Commercial Traffic	Traffic lights	Floor plate Front skirt Post
Step chain roller	Not applicable	Safety lights	Step gap
Location handrail drive	Truss	Drive unit	Direct drive
Handrail shape	U-shape	Usage factor	18 – 20 hours/day
Climate conditions	Indoor Outdoor	Average life span	15 – 20 years

Dimensions and data

Pitless side view

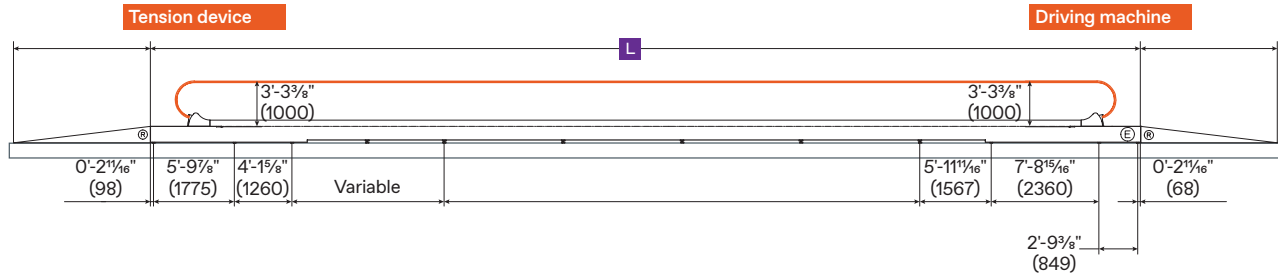

Pitless top view

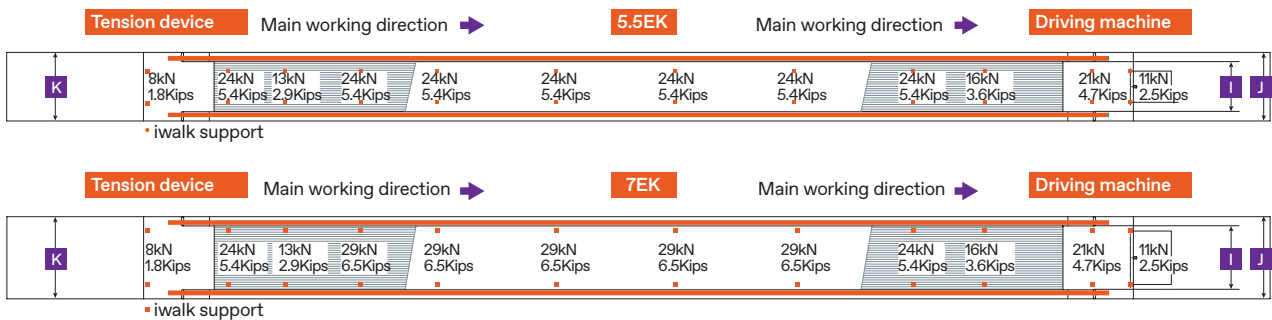

Pitless supports

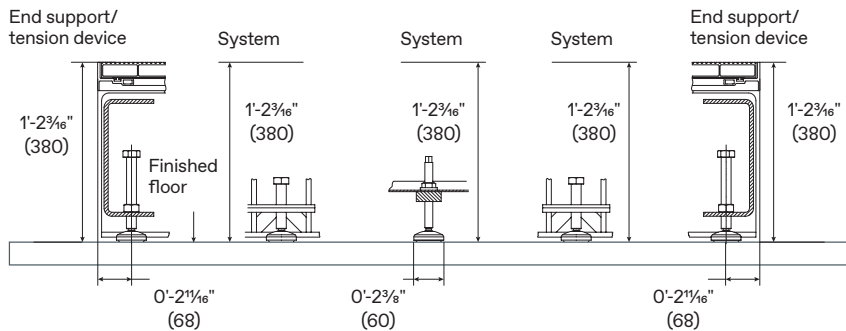

Pitless front view

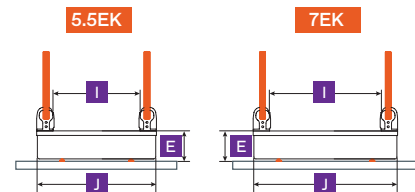

iwalk moving walks

	Shallow pit	Pitless
L Length (m)	Up to 328'-0" (100) ¹	Up to 328'-0" (100) ¹
E Truss depth (mm)	1'-2 3/16" (360)	N/A
F Pit depth (mm)	1'-3" (380)	N/A
G Pit length (mm)	Continuous	N/A
H Finished floor level to floor plate height (mm)	1'-1 3/4" (350 mm)	1'-2 15/16" (379 mm)
I Nominal pallet width (mm)	44" (1110) 55" (1400)	44" (1110) 55" (1400)
J Truss overall width (mm)	4'-11 1/4" (1505) ² 5'-11 1/16" (1805) ³	4'-11 1/4" (1505) ² 5'-11 1/16" (1805) ³
K Pit width (mm)	5'-1 5/8" (1565) ² 6'-1 1/16" (1865) ³	N/A
Middle part truss depth (mm)	1'-2 3/16" (360)	N/A
Middle part pit depth (mm)	1'-3" (380)	N/A

Dimensional data shown here comply with the current ASME A17.1 and CSA B44 Safety Code for Elevators. Local codes may vary from national codes. Consult your local TK Elevator representative for details. Dimensions based on 100 fpm (0.5 m/s).

¹ Reversible only for lengths under 200 feet (61 m) long.

² Dimensions for 44" wide pallet.

³ Dimensions for 55" wide pallet.

OUR CORE PRINCIPLES



ALWAYS THERE

Our passionate goal is to always be there to secure the reliability of mobility equipment, ensuring it provides each passenger with the safest and most comfortable travel experience, thereby helping to make cities the best ever places to live.

elevators and escalators under maintenance

1,100,000

customers in countries

100+

employees

50,000+

locations

900

service available for customers

24/7

service technicians

27,000+

TK Elevator Corporation
788 Circle 75 Parkway SE,
Suite 500
Atlanta, GA 30339
P: +1 844 427 5461
www.tkelevator.com/us

TK Elevator (Canada) Limited
2075 Kennedy Rd., Suite 600,
Scarborough (Ontario) M1T 3V3
P: 416 291-2000
www.tkelevator.com/ca-en



All illustrations and specifications are based on information in effect at time of publication approval.
TK Elevator reserves the right to change specifications or design and to discontinue items without prior notice or obligation.
© 2022 TK Elevator Corporation. | CA License #C11-661371 | 20551 | iwalk_brochure